

# Reference Manual

DOC. REV. 5/15/2008

---

## SPX-5

Eight-channel Solid State  
Switch Serial Peripheral  
Expansion (SPX™) Board



**VERSA**LOGIC  
CORPORATION



[WWW.VERSALOGIC.COM](http://WWW.VERSALOGIC.COM)

3888 Stewart Road  
Eugene, OR 97402  
(541) 485-8575  
Fax (541) 485-5712

Contents Copyright © 2008  
All Rights Reserved

**Notice:**

Although every effort has been made to ensure this document is error-free, VersaLogic makes no representations or warranties with respect to this product and specifically disclaims any implied warranties of merchantability or fitness for any particular purpose.

VersaLogic reserves the right to revise this product and associated documentation at any time without obligation to notify anyone of such changes.

PC/104 and the PC/104 logo are trademarks of the PC/104 Consortium.



**MSPX5**

# Product Release Notes

## **Rev. 1**

- Production release.

## Support Page

The SPX support page, at <http://www.versalogic.com/private/SPX5support.asp>, contains additional information and resources for this product including:

- Reference Manual (PDF format)
- Data sheets and manufacturers' links for chips used in this product
- Utility routines and benchmark software

This is a private page for SPX users that can be accessed only by entering this address directly. It cannot be reached from the VersaLogic homepage.

# Table of Contents

---

- Introduction ..... 1**
  - Description..... 1
    - About SPI..... 1
  - Technical Specifications ..... 2
  - RoHS-Compliance ..... 3
    - About RoHS..... 3
  - Warnings..... 3
    - Electrostatic Discharge ..... 3
  - Technical Support ..... 4
    - Repair Service..... 4
- Physical Details ..... 5**
  - SPX-5 Board Layout..... 5
    - Hardware Assembly..... 6
  - Connector Functions and Interface Cables ..... 7
  - Jumper Summary ..... 7
  - Connector Pinouts..... 8
- Operation ..... 9**
  - Description..... 9
    - SPI Interface ..... 9
    - Applications ..... 10
  - Switch Control Code Example..... 11
- Base Board SPI Registers ..... 12**
  - SPI Data Registers ..... 14

## Description

The VersaLogic SPX-5 is an 8-channel FET switch expansion module designed to be used with EBX-11 Rev 6.xx SPX™ enabled base boards. Its features include:

- Freescale MC33879 Octal Serial Switch
- 24VDC Working Voltage
- 8 High-side/Low-side FET Switches
- 2 Inputs Configurable for PWM
- Load/Fault Detect
- 0.6A – 1.2A Current Limit

VersaLogic SPX boards are a line of I/O expansion boards using the industry standard Serial Peripheral Interface (SPI) bus. These are small 1.2” x 3.775” boards that can be mounted on the PC/104 and PC/104-*Plus* stack using normal standoffs. They can also mount up to two feet away from the base board using custom cabling.

SPX boards are electrically connected to a base board via a 14-pin 2 mm cable. Up to four boards can be daisy-chained together. The SPI bus requires each chip to have a discrete chip-select signal, and the 14-pin interface supplies four chip-select signals. The maximum clock rate is 8 MHz.

Power for SPX boards is supplied through the interface cable. I/O connections on SPX boards are provided through screw terminal/wire connections.

All SPX boards are RoHS compliant and industrial temperature rated.

### ABOUT SPI

The SPI bus specifies four logic signals: SCLK – Serial clock (output from master); MOSI – Master output, slave input (output from master); MISO – Master input, slave output (output from slave); and SS – Slave select (output from master).

The SPI implementation on VersaLogic CPU boards adds additional features, such as hardware interrupt input to the master. The master initiates all SPI transactions. A slave device responds when its slave select is asserted and it receives clock pulses from the master.

Slave selects are controlled in one of two modes: manual or automatic. In automatic mode, the slave select is asserted by the SPI controller when the most significant data byte is written. This initiates a transaction to the specified slave device. In manual mode, the slave select is controlled by the user and any number of data frames can be sent. The user must command the slave select high to complete the transaction.

The SPI clock rate can be software configured to operate at speeds between 1 MHz and 8 MHz. All four common SPI modes are supported through the use of clock polarity and clock phase controls.

## Technical Specifications

*Specifications are typical at 25°C with 5.0V supply unless otherwise noted.*

**Board Size:** 1.2" x 3.775"; SPX compliant

**Storage Temperature:** -40° C to 85° C

**Free Air Operating Temperature:**

-40° C to +85° C

**Power Requirements:**

*Supplied by base board:*

+5.0V ± 5% @ 60 mA (300 mW) load typ.

(Interface cable provides 500 mA total, to be shared by all SPX modules)

*External supply for switched loads:*

+5.5VDC to +26.5VDC, 1.5A

(External supply provided by the user)

**High Side/Low Side Switch:**

8 power MOSFET switches

*Loading:*

All 8ch ON continuous: 180mA per channel

for 1.44A total load for device.

Single channel: 550mA continuous.

**Compatibility:**

SPX – EBX-11 Rev 6 and above compatible

SPI controller (3.3V signaling SPI interface, 4

MHz maximum clock, manual Slave Select)

**Weight:**

TBD

**Compliance:**

RoHS – Full compliance

Specifications are subject to change without notice.

## RoHS-Compliance

The SPX-5 is RoHS-compliant.

### ABOUT ROHS

In 2003, the European Union issued Directive 2002/95/EC regarding the Restriction of the use of certain Hazardous Substances (RoHS) in electrical and electronic equipment.

The RoHS directive requires producers of electrical and electronic equipment to reduce to acceptable levels the presence of six environmentally sensitive substances: lead, mercury, cadmium, hexavalent chromium, and the presence of polybrominated biphenyls (PBB) and polybrominated diphenyl ethers (PBDE) flame retardants, in certain electrical and electronic products sold in the European Union (EU) beginning July 1, 2006.

VersaLogic Corporation is committed to supporting customers with high-quality products and services meeting the European Union's RoHS directive.

## Warnings

### ELECTROSTATIC DISCHARGE

Electrostatic discharge (ESD) can damage boards, disk drives, and other components. The circuit board must only be handled at an ESD workstation. If an approved station is not available, some measure of protection can be provided by wearing a grounded antistatic wrist strap. Keep all plastic away from the board, and do not slide the board over any surface.

After removing the board from its protective wrapper, place the board on a grounded, static-free surface, component side up. Use an antistatic foam pad if available.

The board should also be protected inside a closed metallic anti-static envelope during shipment or storage.

## Technical Support

If you are unable to solve a problem with this manual please visit the SPX Product Support web page listed below. If you have further questions, contact VersaLogic technical support at (541) 485-8575. VersaLogic technical support engineers are also available via e-mail at [Support@VersaLogic.com](mailto:Support@VersaLogic.com).

### SPX Support Website

<http://www.versalogic.com/private/spx5support.asp>

#### REPAIR SERVICE

If your product requires service, you must obtain a Returned Material Authorization (RMA) number by calling (541) 485-8575.

Please provide the following information:

- Your name, the name of your company and your phone number
- The name of a technician or engineer that can be contact if any questions arise.
- Quantity of items being returned
- The model and serial number (barcode) of each item
- A detailed description of the problem
- Steps you have taken to resolve or recreate the problem
- The return shipping address

#### Warranty Repair

All parts and labor charges are covered, including return shipping charges for UPS Ground delivery to United States addresses.

#### Non-warranty Repair

All non-warranty repairs are subject to diagnosis and labor charges, parts charges and return shipping fees. Please specify the shipping method you prefer and provide a purchase order number for invoicing the repair.

#### Note

Please mark the RMA number clearly on the outside of the box before returning. Failure to do so can delay the processing of your return.

## SPX-5 Board Layout

The figure below shows the dimensions of the SPX-5 board, as well as the location of connectors, jumpers, and mounting holes.

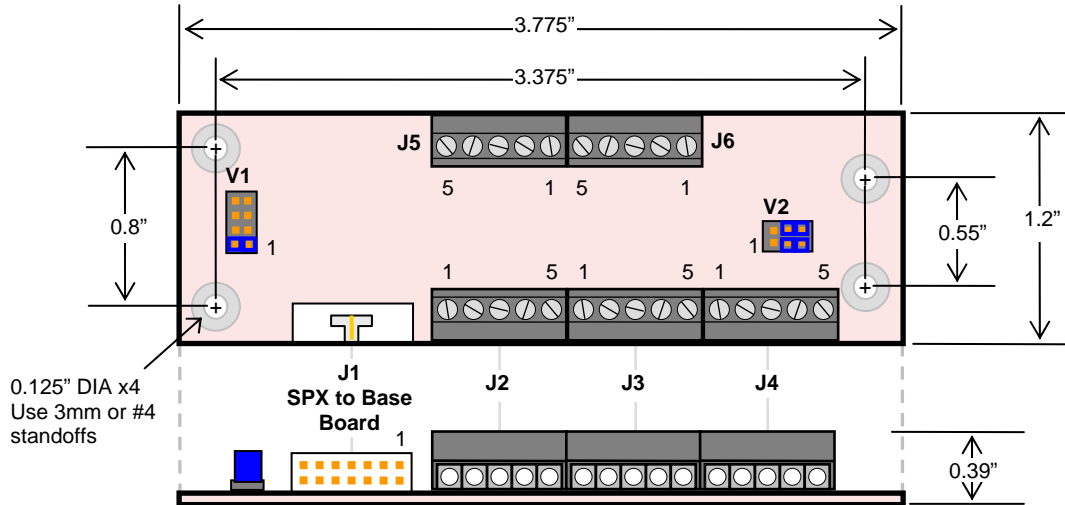
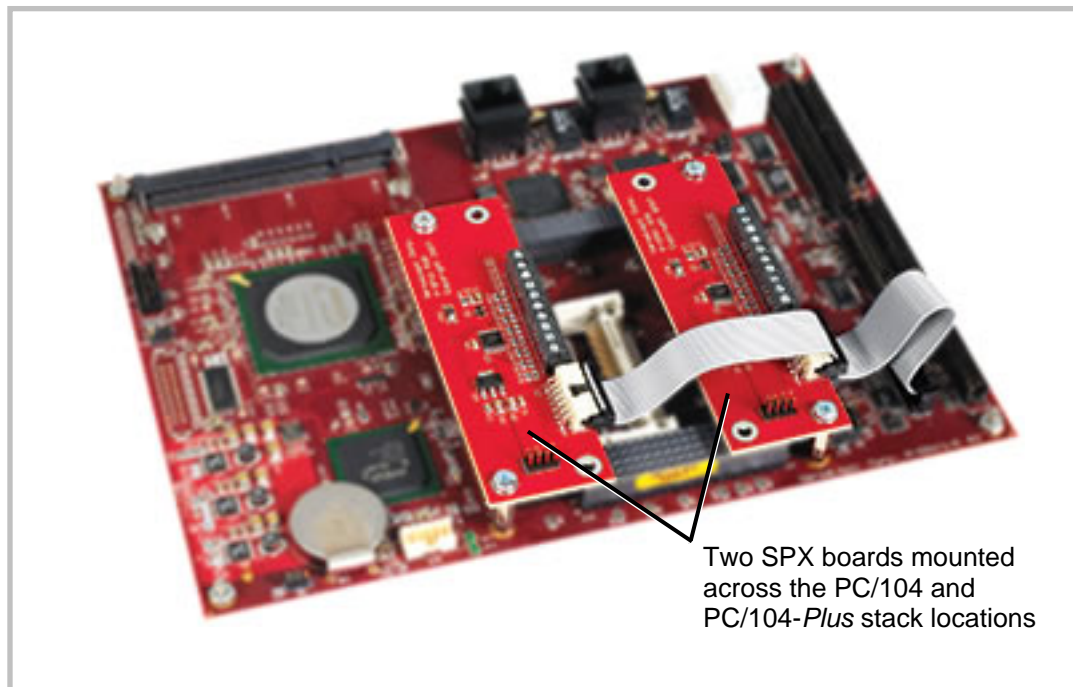

**Figure 1. SPX-5 Board Layout**  
(Not to scale. All dimensions in inches.)

## HARDWARE ASSEMBLY

The SPX-5 mounts on two hardware standoffs using the corner mounting holes. These standoffs are secured to the board, typically across the PC/104 and PC/104-*Plus* stack locations, using pan head screws, shown in Figure 2.

Standoffs and screws are available as part number VL-HDW-101.



**Figure 2. SPX Board Mounting**

## Connector Functions and Interface Cables

The following table shows the function of each connector, as well as mating connectors and cables.

**Table 1: Connector Functions and Interface Cables**

| Connector | Function          | Mating Connector                   | Transition Cable     | Cable Description                        |
|-----------|-------------------|------------------------------------|----------------------|--|
| J1        | SPX to Base Board | FCI 89361-714LF or equivalent      | CBR-1401<br>CBR-1402 | 2 SPX Module Cable<br>4 SPX Module Cable |
| J2        | Switch 1 and 2    | Bare wires to 5-pin screw terminal | –                    | 16-28 AWG wire                           |
| J3        | Switch 3 and 4    | Bare wires to 5-pin screw terminal | –                    | 16-28 AWG wire                           |
| J4        | PWM Input         | Bare wires to 5-pin screw terminal | –                    | 16-28 AWG wire                           |
| J5        | Switch 5 and 6    | Bare wires to 5-pin screw terminal | –                    | 16-28 AWG wire                           |
| J6        | Switch 7 and 8    | Bare wires to 5-pin screw terminal | –                    | 16-28 AWG wire                           |

## Jumper Summary

**Table 2: Jumper Summary**

| Jumper Block | Description  | As Shipped |
|--------------|--|------------|
| V1           | <b>Slave Select.</b><br>[1-2] = Slave Select 0<br>[3-4] = Slave Select 1<br>[5-6] = Slave Select 2<br>[7-8] = Slave Select 3 | [1-2]      |
| *V2[1-3-5]   | <b>Switch 6 Input Select.</b><br>[1-3] = PWM input<br>[3-5] = SPI input  | [3-5]      |
| *V2[2-4-6]   | <b>Switch 5 Input Select.</b><br>[2-4] = PWM input<br>[4-6] = SPI input  | [4-6]      |

\* Note the orientation of the V2 jumpers. Pins 2-4-6 control switch 5 input, and pins 1-3-5 control switch 6 input.

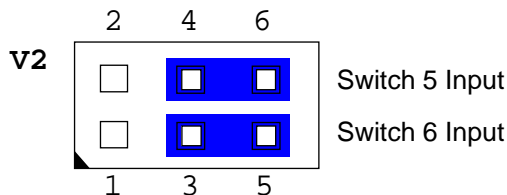

## Connector Pinouts

**Table 3: J1 Connector Pinout**

| Pin | Signal Name | Description         |
|-----|-------------|---------------------|
| 1   | V5_0        | +5.0V               |
| 2   | SCLK        | Serial Clock        |
| 3   | GND         | Ground              |
| 4   | MISO        | Master In Slave Out |
| 5   | GND         | Ground              |
| 6   | MOSI        | Master Out Slave In |
| 7   | GND         | Ground              |
| 8   | SS0#        | Slave Select 0      |
| 9   | SS1#        | Slave Select 1      |
| 10  | SS2#        | Slave Select 2      |
| 11  | SS3#        | Slave Select 3      |
| 12  | GND         | Ground              |
| 13  | SINT#       | SPI Interrupt       |
| 14  | V5_0        | +5.0V               |

**Table 4: J2–J6 Connector Pinouts**

| Connector | Pin | Signal Name | Description      |
|-----------|-----|-------------|------------------|
| <b>J2</b> | 1   | D1          | Switch 1 drain.  |
|           | 2   | S1          | Switch 1 source. |
|           | 3   | D2          | Switch 2 drain.  |
|           | 4   | S2          | Switch 2 source. |
|           | 5   | GND         | Ground.          |
| <b>J3</b> | 1   | D3          | Switch 3 drain.  |
|           | 2   | S3          | Switch 3 source. |
|           | 3   | D4          | Switch 4 drain.  |
|           | 4   | S4          | Switch 4 source. |
|           | 5   | GND         | Ground.          |
| <b>J4</b> | 1   | PWM_IN1     | PWM input 1.     |
|           | 2   | PWM_IN2     | PWM input 2.     |
|           | 3   | NC          | Not connected.   |
|           | 4   | NC          | Not connected.   |
|           | 5   | GND         | Ground.          |
| <b>J5</b> | 1   | D5          | Switch 5 drain.  |
|           | 2   | S5          | Switch 5 source. |
|           | 3   | D6          | Switch 6 drain.  |
|           | 4   | S6          | Switch 6 source. |
|           | 5   | GND         | Ground.          |
| <b>J6</b> | 1   | D7          | Switch 7 drain.  |
|           | 2   | S7          | Switch 7 source. |
|           | 3   | D8          | Switch 8 drain.  |
|           | 4   | S8          | Switch 8 source. |
|           | 5   | GND         | Ground.          |

## Description

The SPX-5 incorporates the Freescale MC33879 device, which provides eight power MOSFET switches that can be configured to drive small industrial loads such as solenoid valves, fans, and lights. It is controlled through the VersaLogic SPX (SPI) interface, but has two channels that can be configured via jumpers to accept direct control signals such as PWM, GPIO, or pushbutton inputs. These inputs are 5V tolerant and can accept 3.3V or 5V CMOS outputs.

You must provide an external voltage source to supply the intended load(s). The switches are independent and can use individual sources. The SPX-5 has a built-in 13.6VDC gate drive source for driving the power MOSFETs. Each MOSFET switch incorporates automatic over-current and over-temperature fault detection and will shutoff when the load current is within the range of 0.6A to 1.2A or when the device temperature is within the range of 155°C to 185°C. When the over-current/temperature condition is relieved, the device will return to its previous state. A fault register indicates when an error condition has occurred.

**Note:** The switch can oscillate if subjected to continuous high loads and temperatures. The MC33879 also incorporates internal voltage clamping of +45VDC and -20VDC for low and high side configurations respectively.

See the [Freescale MC33879 Datasheet](#) for more information.

### SPI INTERFACE

The MC33879 is controlled with a 16-bit SPI frame as shown in the following tables.

**Table 5: Command Register Bit Assignments**

| MSB                    |                        |                        |                        |                        |                        |                        |                        |                        |            |            |            |            |            | LSB        |            |
|------------------------|------------------------|------------------------|------------------------|------------------------|------------------------|------------------------|------------------------|------------------------|------------|------------|------------|------------|------------|------------|------------|
| Bit 15                 | Bit 14                 | Bit 13                 | Bit 12                 | Bit 11                 | Bit 10                 | Bit 9                  | Bit 8                  | Bit 7                  | Bit 6      | Bit 5      | Bit 4      | Bit 3      | Bit 2      | Bit 1      | Bit 0      |
| ON/<br>OFF             | ON/<br>OFF             | ON/<br>OFF             | ON/<br>OFF             | ON/<br>OFF             | ON/<br>OFF             | ON/<br>OFF             | ON/<br>OFF             | ON/<br>OFF             | ON/<br>OFF | ON/<br>OFF | ON/<br>OFF | ON/<br>OFF | ON/<br>OFF | ON/<br>OFF | ON/<br>OFF |
| Open<br>Load<br>Detect | Open<br>Load<br>Detect | Open<br>Load<br>Detect | Open<br>Load<br>Detect | Open<br>Load<br>Detect | Open<br>Load<br>Detect | Open<br>Load<br>Detect | Open<br>Load<br>Detect | Open<br>Load<br>Detect | OUT 8      | OUT 7      | OUT 6      | OUT 5      | OUT 4      | OUT 3      | OUT 2      |
| 8                      | 7                      | 6                      | 5                      | 4                      | 3                      | 2                      | 1                      |                        |            |            |            |            |            |            |            |

**Table 6: Fault Register Bit Assignments**

| MSB    |        |        |        |        |        |       |       |                 |                 |                 |                 |                 |                 | LSB             |                 |
|--------|--------|--------|--------|--------|--------|-------|-------|-----------------|-----------------|-----------------|-----------------|-----------------|-----------------|-----------------|-----------------|
| Bit 15 | Bit 14 | Bit 13 | Bit 12 | Bit 11 | Bit 10 | Bit 9 | Bit 8 | Bit 7           | Bit 6           | Bit 5           | Bit 4           | Bit 3           | Bit 2           | Bit 1           | Bit 0           |
| 0      | 0      | 0      | 0      | 0      | 0      | 0     | 0     | OUT 8<br>Status | OUT 7<br>Status | OUT 6<br>Status | OUT 5<br>Status | OUT 4<br>Status | OUT 3<br>Status | OUT 2<br>Status | OUT 1<br>Status |

**APPLICATIONS**

Figure 3 provides a simplified view of possible applications.

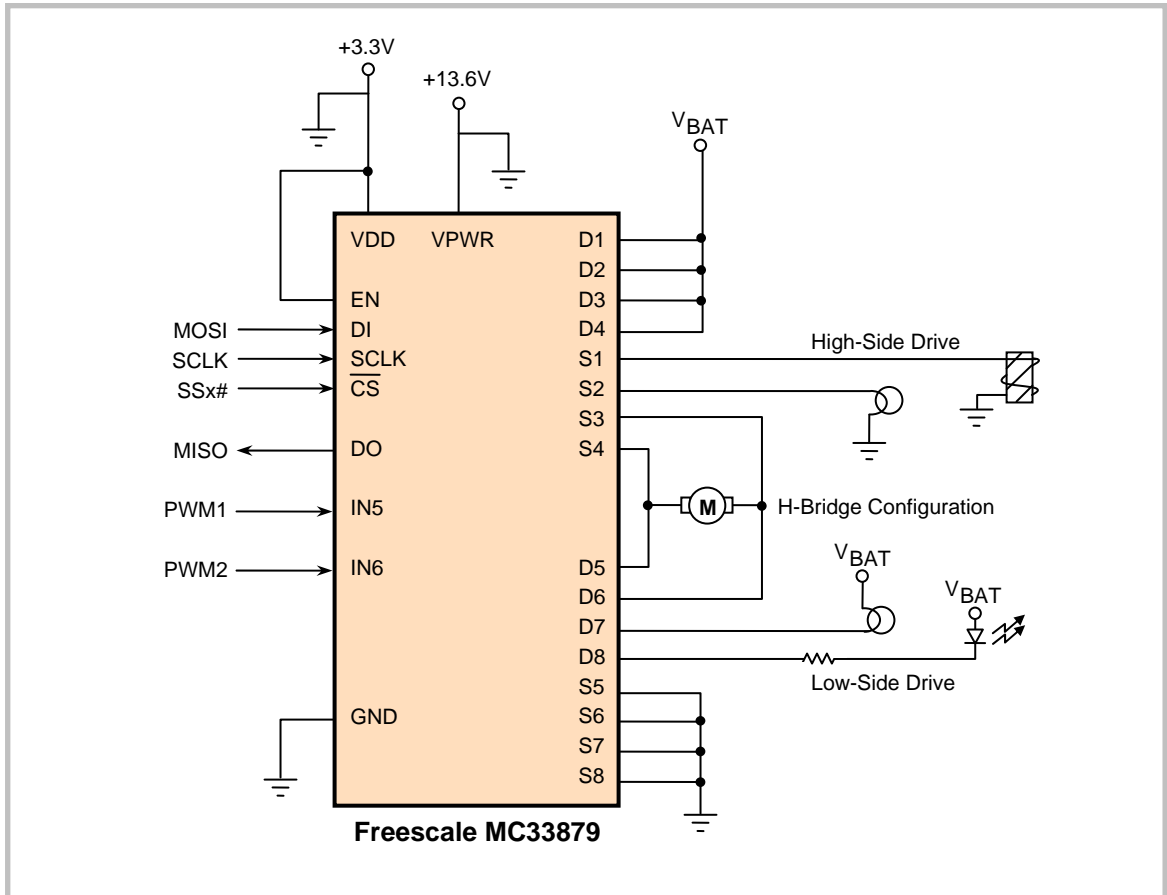

**Figure 3. Simplified Application Diagram**

## Switch Control Code Example

The following code example shows how to configure the base board's SPX registers for the SPX-5 and turns on switch 3 (SPX-5 J3 pins 1 and 2). The test setup is configured with an appropriate external voltage supply for the load driven and the SPX-5 jumpered for SS0#.

```

; Setup SPI configuration registers
MOV  DX, 0x1D9
MOV  AL, 0x20          ;SPISTATUS: 4MHz, no IRQ, left-shift data
OUT  DX, AL

MOV  DX, 0x1D8
MOV  AL, 0x59          ;SPICONTROL: SCLK idle low, falling edge,
OUT  DX, AL           ;16bit frame, manual SS0# (asserted now)

; Output MC33879 switch command
MOV  DX, 0x1DC
MOV  AX, 0xFF04        ;SPIDATA3: fault detect current ON (all),
OUT  DX, AX           ;SPIDATA2: MOSFET switch 3 ON
CALL BUSY              ;Poll BUSY flag to wait for SPI transaction

; Complete SPI transaction
MOV  DX, 0x1D8
MOV  AL, 0x58          ;SPICONTROL: De-assert SS0#
OUT  DX, AL

; Read Fault Status Register contents
MOV  DX, 0x1DC
IN   AL, DX           ;MC33879 fault status now in AL

; Wait loop for SPI transaction
BUSY: MOV  DX, 0x1D9
      IN   AL, DX      ;Read SPISTATUS
      AND  AL, 0x01    ;Isolate BUSY flag
      JNZ  BUSY        ;Loop if SPI transaction not complete

```

# Base Board SPI Registers



The following tables describe the SPI control and data registers of the EBX-11 Rev. 6.00 and later. This is the standard set of SPI registers for VersaLogic CPU boards with an SPX interface. See the appropriate base-board reference manual for details and updates.

## SPICONTROL (READ/WRITE) 1D8h

| D7   | D6   | D5      | D4      | D3     | D2  | D1  | D0  |
|------|------|---------|---------|--------|-----|-----|-----|
| CPOL | CPHA | SPILEN1 | SPILEN0 | MAN_SS | SS2 | SS1 | SS0 |

Table 7: SPI Control Register 1 Bit Assignments

| Bit     | Mnemonic | Description  |   |         |              |              |   |       |   |                     |        |   |   |                               |   |   |        |                               |   |   |   |                                |   |   |   |                                |   |   |   |                                     |   |   |   |  |   |   |   |   |
|---------|----------|--|---|---------|--------------|--------------|---|-------|---|---------------------|--------|---|---|-------------------------------|---|---|--------|-------------------------------|---|---|---|--------------------------------|---|---|---|--------------------------------|---|---|---|-------------------------------------|---|---|---|--|---|---|---|---|
| D7      | CPOL     | <b>SPI Clock Polarity</b> – Sets the SCLK idle state.<br>0 = SCLK idles low<br>1 = SCLK idles high   |   |         |              |              |   |       |   |                     |        |   |   |                               |   |   |        |                               |   |   |   |                                |   |   |   |                                |   |   |   |                                     |   |   |   |  |   |   |   |   |
| D6      | CPHA     | <b>SPI Clock Phase</b> – Sets the SCLK edge on which valid data will be read.<br>0 = Data read on rising edge<br>1 = Data read on falling edge   |   |         |              |              |   |       |   |                     |        |   |   |                               |   |   |        |                               |   |   |   |                                |   |   |   |                                |   |   |   |                                     |   |   |   |  |   |   |   |   |
| D5-D4   | SPILEN   | <b>SPI Frame Length</b> – Sets the SPI frame length. This selection works in manual and auto slave select modes.<br><br><table border="1"> <thead> <tr> <th>SPILEN1</th> <th>SPILEN0</th> <th>Frame Length</th> </tr> </thead> <tbody> <tr> <td>0</td> <td>0</td> <td>8-bit</td> </tr> <tr> <td>0</td> <td>1</td> <td>16-bit</td> </tr> <tr> <td>1</td> <td>0</td> <td>24-bit</td> </tr> <tr> <td>1</td> <td>1</td> <td>32-bit</td> </tr> </tbody> </table>  | SPILEN1                                       | SPILEN0 | Frame Length | 0            | 0 | 8-bit | 0 | 1                   | 16-bit | 1 | 0 | 24-bit                        | 1 | 1 | 32-bit |                               |   |   |   |                                |   |   |   |                                |   |   |   |                                     |   |   |   |  |   |   |   |   |
| SPILEN1 | SPILEN0  | Frame Length   |   |         |              |              |   |       |   |                     |        |   |   |                               |   |   |        |                               |   |   |   |                                |   |   |   |                                |   |   |   |                                     |   |   |   |  |   |   |   |   |
| 0       | 0        | 8-bit  |   |         |              |              |   |       |   |                     |        |   |   |                               |   |   |        |                               |   |   |   |                                |   |   |   |                                |   |   |   |                                     |   |   |   |  |   |   |   |   |
| 0       | 1        | 16-bit   |   |         |              |              |   |       |   |                     |        |   |   |                               |   |   |        |                               |   |   |   |                                |   |   |   |                                |   |   |   |                                     |   |   |   |  |   |   |   |   |
| 1       | 0        | 24-bit   |   |         |              |              |   |       |   |                     |        |   |   |                               |   |   |        |                               |   |   |   |                                |   |   |   |                                |   |   |   |                                     |   |   |   |  |   |   |   |   |
| 1       | 1        | 32-bit   |   |         |              |              |   |       |   |                     |        |   |   |                               |   |   |        |                               |   |   |   |                                |   |   |   |                                |   |   |   |                                     |   |   |   |  |   |   |   |   |
| D3      | MAN_SS   | <b>SPI Manual Slave Select Mode</b> – This bit determines whether the slave select lines are controlled through the user software or are automatically controlled by a write operation to SPIDATA3 (1DDh). If MAN_SS = 0, then the slave select operates automatically; if MAN_SS = 1, then the slave select line is controlled manually through SPICONTROL bits SS2, SS1, and SS0.<br><br>0 = Automatic, default<br>1 = Manual  |   |         |              |              |   |       |   |                     |        |   |   |                               |   |   |        |                               |   |   |   |                                |   |   |   |                                |   |   |   |                                     |   |   |   |  |   |   |   |   |
| D2-D0   | SS       | <b>SPI Slave Select</b> – These bits select which slave select will be asserted. The SSx# pin on the base board will be directly controlled by these bits when MAN_SS = 1.<br><br><table border="1"> <thead> <tr> <th>SS2</th> <th>SS1</th> <th>SS0</th> <th>Slave Select</th> </tr> </thead> <tbody> <tr> <td>0</td> <td>0</td> <td>0</td> <td>None, port disabled</td> </tr> <tr> <td>0</td> <td>0</td> <td>1</td> <td>SPX Slave Select 0, J17 pin-8</td> </tr> <tr> <td>0</td> <td>1</td> <td>0</td> <td>SPX Slave Select 1, J17 pin-9</td> </tr> <tr> <td>0</td> <td>1</td> <td>1</td> <td>SPX Slave Select 2, J17 pin-10</td> </tr> <tr> <td>1</td> <td>0</td> <td>0</td> <td>SPX Slave Select 3, J17 pin-11</td> </tr> <tr> <td>1</td> <td>0</td> <td>1</td> <td>On-Board A/D Converter Slave Select</td> </tr> <tr> <td>1</td> <td>1</td> <td>0</td> <td>On-Board Digital I/O Ch 0-Ch 15 Slave Select</td> </tr> <tr> <td>1</td> <td>1</td> <td>1</td> <td>On-Board Digital I/O Ch 16-Ch 31 Slave Select</td> </tr> </tbody> </table> | SS2   | SS1     | SS0          | Slave Select | 0 | 0     | 0 | None, port disabled | 0      | 0 | 1 | SPX Slave Select 0, J17 pin-8 | 0 | 1 | 0      | SPX Slave Select 1, J17 pin-9 | 0 | 1 | 1 | SPX Slave Select 2, J17 pin-10 | 1 | 0 | 0 | SPX Slave Select 3, J17 pin-11 | 1 | 0 | 1 | On-Board A/D Converter Slave Select | 1 | 1 | 0 | On-Board Digital I/O Ch 0-Ch 15 Slave Select | 1 | 1 | 1 | On-Board Digital I/O Ch 16-Ch 31 Slave Select |
| SS2     | SS1      | SS0  | Slave Select                                  |         |              |              |   |       |   |                     |        |   |   |                               |   |   |        |                               |   |   |   |                                |   |   |   |                                |   |   |   |                                     |   |   |   |  |   |   |   |   |
| 0       | 0        | 0  | None, port disabled                           |         |              |              |   |       |   |                     |        |   |   |                               |   |   |        |                               |   |   |   |                                |   |   |   |                                |   |   |   |                                     |   |   |   |  |   |   |   |   |
| 0       | 0        | 1  | SPX Slave Select 0, J17 pin-8                 |         |              |              |   |       |   |                     |        |   |   |                               |   |   |        |                               |   |   |   |                                |   |   |   |                                |   |   |   |                                     |   |   |   |  |   |   |   |   |
| 0       | 1        | 0  | SPX Slave Select 1, J17 pin-9                 |         |              |              |   |       |   |                     |        |   |   |                               |   |   |        |                               |   |   |   |                                |   |   |   |                                |   |   |   |                                     |   |   |   |  |   |   |   |   |
| 0       | 1        | 1  | SPX Slave Select 2, J17 pin-10                |         |              |              |   |       |   |                     |        |   |   |                               |   |   |        |                               |   |   |   |                                |   |   |   |                                |   |   |   |                                     |   |   |   |  |   |   |   |   |
| 1       | 0        | 0  | SPX Slave Select 3, J17 pin-11                |         |              |              |   |       |   |                     |        |   |   |                               |   |   |        |                               |   |   |   |                                |   |   |   |                                |   |   |   |                                     |   |   |   |  |   |   |   |   |
| 1       | 0        | 1  | On-Board A/D Converter Slave Select           |         |              |              |   |       |   |                     |        |   |   |                               |   |   |        |                               |   |   |   |                                |   |   |   |                                |   |   |   |                                     |   |   |   |  |   |   |   |   |
| 1       | 1        | 0  | On-Board Digital I/O Ch 0-Ch 15 Slave Select  |         |              |              |   |       |   |                     |        |   |   |                               |   |   |        |                               |   |   |   |                                |   |   |   |                                |   |   |   |                                     |   |   |   |  |   |   |   |   |
| 1       | 1        | 1  | On-Board Digital I/O Ch 16-Ch 31 Slave Select |         |              |              |   |       |   |                     |        |   |   |                               |   |   |        |                               |   |   |   |                                |   |   |   |                                |   |   |   |                                     |   |   |   |  |   |   |   |   |

**SPISTATUS (READ/WRITE) 1D9h**

| D7      | D6      | D5      | D4      | D3        | D2        | D1     | D0   |
|---------|---------|---------|---------|-----------|-----------|--------|------|
| IRQSEL1 | IRQSEL0 | SPICLK1 | SPICLK0 | HW_IRQ_EN | LSBIT_1ST | HW_INT | BUSY |

**Table 8: SPI Control Register 2 Bit assignments**

| Bit     | Mnemonic  | Description  |         |         |           |   |   |           |   |   |           |   |   |           |   |   |           |
|---------|-----------|--|---------|---------|-----------|---|---|-----------|---|---|-----------|---|---|-----------|---|---|-----------|
| D7-D6   | IRQSEL    | <p><b>IRQ Select</b> – These bits select which IRQ will be asserted when a hardware interrupt from a connected SPI device occurs. The HW_IRQ_EN bit must be set to enable SPI IRQ functionality.</p> <table border="1"> <thead> <tr> <th>IRQSEL1</th> <th>IRQSEL0</th> <th>IRQ</th> </tr> </thead> <tbody> <tr> <td>0</td> <td>0</td> <td>IRQ3</td> </tr> <tr> <td>0</td> <td>1</td> <td>IRQ4</td> </tr> <tr> <td>1</td> <td>0</td> <td>IRQ5</td> </tr> <tr> <td>1</td> <td>1</td> <td>IRQ10</td> </tr> </tbody> </table> <p><b>Note:</b> The on-board digital I/O chips must be configured for open-drain and mirrored interrupts in order for any SPI device to use hardware interrupts.</p> | IRQSEL1 | IRQSEL0 | IRQ       | 0 | 0 | IRQ3      | 0 | 1 | IRQ4      | 1 | 0 | IRQ5      | 1 | 1 | IRQ10     |
| IRQSEL1 | IRQSEL0   | IRQ  |         |         |           |   |   |           |   |   |           |   |   |           |   |   |           |
| 0       | 0         | IRQ3   |         |         |           |   |   |           |   |   |           |   |   |           |   |   |           |
| 0       | 1         | IRQ4   |         |         |           |   |   |           |   |   |           |   |   |           |   |   |           |
| 1       | 0         | IRQ5   |         |         |           |   |   |           |   |   |           |   |   |           |   |   |           |
| 1       | 1         | IRQ10  |         |         |           |   |   |           |   |   |           |   |   |           |   |   |           |
| D5-D4   | SPICLK    | <p><b>SPI SCLK Frequency</b> – These bits set the SPI clock frequency.</p> <table border="1"> <thead> <tr> <th>SPICLK1</th> <th>SPICLK0</th> <th>Frequency</th> </tr> </thead> <tbody> <tr> <td>0</td> <td>0</td> <td>1.042 MHz</td> </tr> <tr> <td>0</td> <td>1</td> <td>2.083 MHz</td> </tr> <tr> <td>1</td> <td>0</td> <td>4.167 MHz</td> </tr> <tr> <td>1</td> <td>1</td> <td>8.333 MHz</td> </tr> </tbody> </table>   | SPICLK1 | SPICLK0 | Frequency | 0 | 0 | 1.042 MHz | 0 | 1 | 2.083 MHz | 1 | 0 | 4.167 MHz | 1 | 1 | 8.333 MHz |
| SPICLK1 | SPICLK0   | Frequency  |         |         |           |   |   |           |   |   |           |   |   |           |   |   |           |
| 0       | 0         | 1.042 MHz  |         |         |           |   |   |           |   |   |           |   |   |           |   |   |           |
| 0       | 1         | 2.083 MHz  |         |         |           |   |   |           |   |   |           |   |   |           |   |   |           |
| 1       | 0         | 4.167 MHz  |         |         |           |   |   |           |   |   |           |   |   |           |   |   |           |
| 1       | 1         | 8.333 MHz  |         |         |           |   |   |           |   |   |           |   |   |           |   |   |           |
| D3      | HW_IRQ_EN | <p><b>Hardware IRQ Enable</b> – Enables or disables the use of the selected IRQ (IRQSEL) by an SPI device.<br/>0 = SPI IRQ disabled, default<br/>1 = SPI IRQ enabled</p> <p><b>Note:</b> The selected IRQ is shared with PC/104 ISA bus devices. CMOS settings must be configured for the desired ISA IRQ.</p>   |         |         |           |   |   |           |   |   |           |   |   |           |   |   |           |
| D2      | LSBIT_1ST | <p><b>SPI Shift Direction</b> – Controls the SPI shift direction of the SPIDATA registers. The direction can be shifted toward the least significant bit or the most significant bit.<br/>0 = SPIDATA data is left-shifted (MSbit first), default<br/>1 = SPIDATA data is right-shifted (LSbit first)</p>  |         |         |           |   |   |           |   |   |           |   |   |           |   |   |           |
| D1      | HW_INT    | <p><b>SPI Device Interrupt State</b> – This bit is a status flag that indicates when the hardware SPX signal SINT# is asserted.<br/>0 = Hardware interrupt on SINT# is deasserted<br/>1 = Interrupt is present on SINT#</p> <p>This bit is read-only and is cleared when the SPI device's interrupt is cleared.</p>  |         |         |           |   |   |           |   |   |           |   |   |           |   |   |           |
| D0      | BUSY      | <p><b>SPI Busy Flag</b> – This bit is a status flag that indicates when an SPI transaction is underway.<br/>0 = SPI bus idle<br/>1 = SCLK is clocking data in and out of the SPIDATA registers</p> <p>This bit is read-only.</p>   |         |         |           |   |   |           |   |   |           |   |   |           |   |   |           |

**SPI DATA REGISTERS****SPIDATA0 (READ/WRITE) 1DAh**

|           |           |           |           |           |           |           |           |
|-----------|-----------|-----------|-----------|-----------|-----------|-----------|-----------|
| <b>D7</b> | <b>D6</b> | <b>D5</b> | <b>D4</b> | <b>D3</b> | <b>D2</b> | <b>D1</b> | <b>D0</b> |
| MSbit     |           |           |           |           |           |           | LSbit     |

**SPIDATA1 (READ/WRITE) 1DBh**

|           |           |           |           |           |           |           |           |
|-----------|-----------|-----------|-----------|-----------|-----------|-----------|-----------|
| <b>D7</b> | <b>D6</b> | <b>D5</b> | <b>D4</b> | <b>D3</b> | <b>D2</b> | <b>D1</b> | <b>D0</b> |
| MSbit     |           |           |           |           |           |           | LSbit     |

**SPIDATA2 (READ/WRITE) 1DCh**

|           |           |           |           |           |           |           |           |
|-----------|-----------|-----------|-----------|-----------|-----------|-----------|-----------|
| <b>D7</b> | <b>D6</b> | <b>D5</b> | <b>D4</b> | <b>D3</b> | <b>D2</b> | <b>D1</b> | <b>D0</b> |
| MSbit     |           |           |           |           |           |           | LSbit     |

**SPIDATA3 (READ/WRITE) 1DDh**

|           |           |           |           |           |           |           |           |
|-----------|-----------|-----------|-----------|-----------|-----------|-----------|-----------|
| <b>D7</b> | <b>D6</b> | <b>D5</b> | <b>D4</b> | <b>D3</b> | <b>D2</b> | <b>D1</b> | <b>D0</b> |
| MSbit     |           |           |           |           |           |           | LSbit     |

SPIDATA3 contains the most significant byte (MSB) of the SPI data word. A write to this register will initiate the SPI clock and, if the MAN\_SS bit = 0, will also assert a slave select to begin an SPI bus transaction. Increasing frame sizes from 8-bit use the lowest address for the least significant byte of the SPI data word; for example, the LSB of a 24-bit frame would be SPIDATA1. Data is sent according to the LSBIT\_1ST setting. When LSBIT\_1ST = 0, the MSbit of SPIDATA3 is sent first, and received data will be shifted into the LSbit of the selected frame size set in the SPILEN field. When LSBIT\_1ST = 1, the LSbit of the selected frame size is sent first, and the received data will be shifted into the MSbit of SPIDATA3.